

RIGHT HAND SHOWN, LEFT HAND OPPOSITE

MATERIAL LIST			
ITM	DESCRIPTION	LENGTH	QTY
1	Angle-S 2.36 x 2.36x 0.25	23.75	1
2	Bar-Rect-SC 2.36x 0.25	33.3	1
3	Angle-S 2.36x 2.36x 0.25	35.75	1

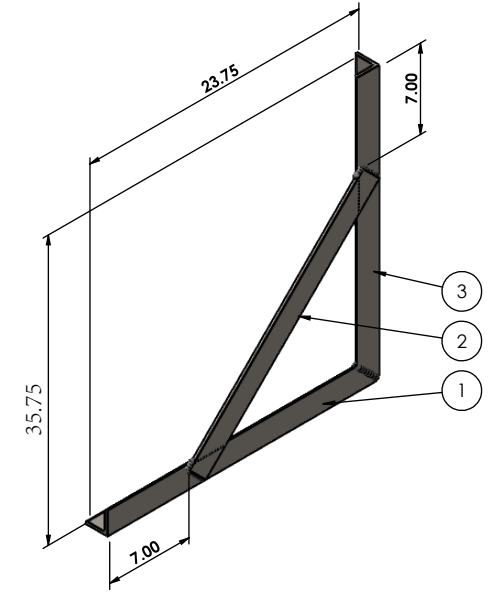
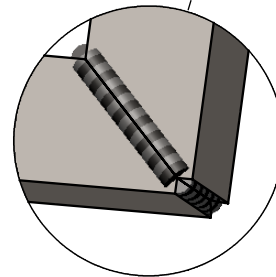
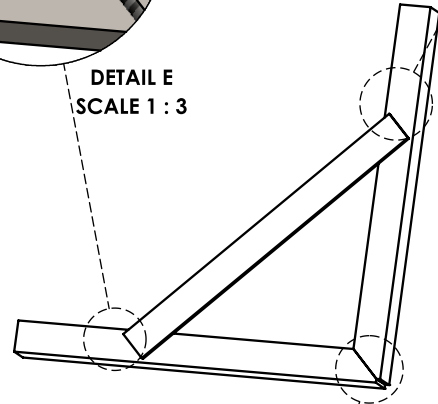
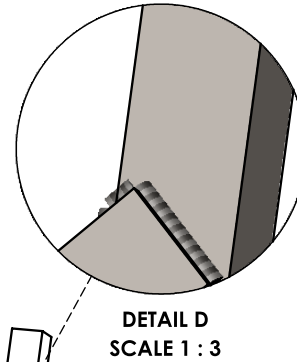
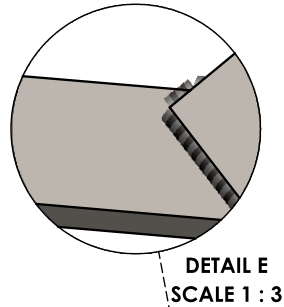
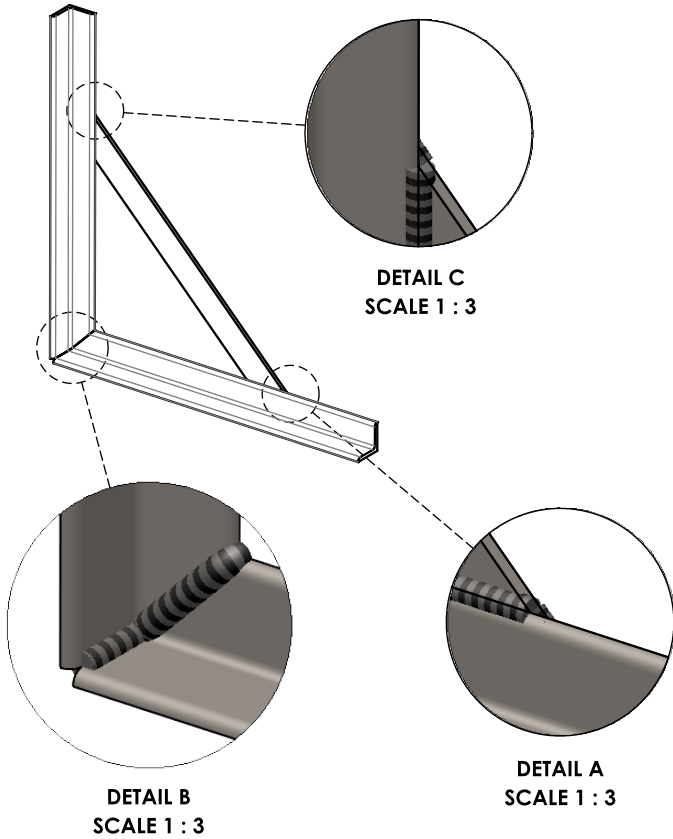

NOTE 1:

- IF DEPTH OR HEIGHT OF BRACKET IS 18IN. OR LESS, DISTANCE BETWEEN END OF ANGLE AND CORNER OF FLATBAR IS PERMITTED TO BE 1IN.

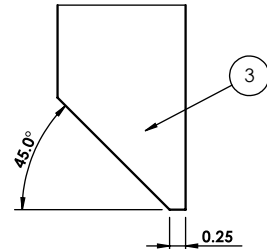
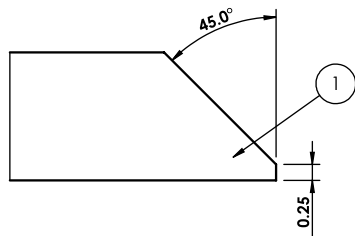

JIMEXS
HARDWARE

1 866 447-5656 / INFO@JIMEXS.COM

REVISIONS		
REV.	DESCRIPTION	DATE
B	ADDED REVISION TABLE, CHANGED FLATBAR PLACEMENT AND LENGTH AND UPDATED SHEET FORMAT	09/05/2016
C	CORRECTED MIS-LABELED MATERIAL REFERENCE IN DESCRIPTION	6/14/2016

PartNo: 136-001 **REV-C**

Material: **ASTM A36 Steel**

Descr: 24D" x 36H" Regular steel toolbox bracket RH

Client: _____ Date: **10/18/2018**

Drawn By: _____ Sheet Size: 8.268in*11.693in Weight(lb): _____ Scale: 1:12 SHEET 1 OF 1

Dimensions are in inches unless otherwise specified